

## Nadelhalter mit Hartmetalleinsätzen im Maulbereich Needle holders with tungsten-carbide inserts in the jaws

Porte-aiguilles avec des inserts de carbure de tungstène dans les mors  
Porte-agujas con insertos de carburo tungsteno en las bocas  
Port'aghi con inserti in carburo di tungsteno

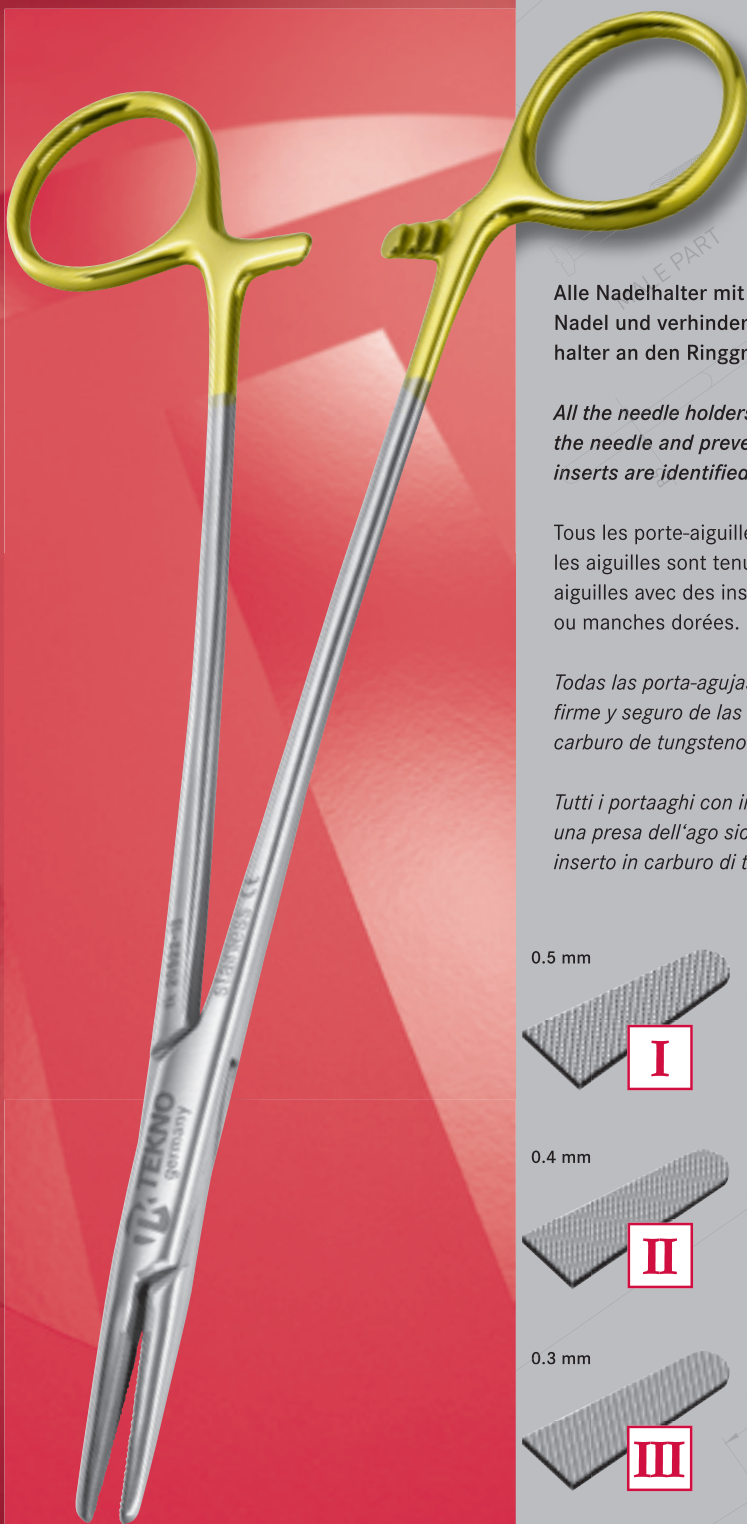

Alle Nadelhalter mit „tucar“ Hartmetalleinsätzen bieten einen sicheren, festen Halt der Nadel und verhindern deren Verdrehen. Zur Kennzeichnung sind alle Hartmetall-Nadelhalter an den Ringgriffen bzw. den Branchen vergoldet.

All the needle holders with “tucar” tungsten-carbide inserts offer a safe and secure grip of the needle and prevent the twisting of the same. Needle holders with tungsten-carbide inserts are identified by gold-plated rings or handles.

Tous les porte-aiguilles avec des inserts «tucar» de carbure de tungstène garantissent que les aiguilles sont tenues sûres et fortes et qu'elles ne peuvent pas se tordre. Les portes aiguilles avec des inserts de tungstène de carbure peuvent être reconnus à leurs bagues ou manches dorées.

Todas las porta-agujas “tucar” con los insertos de carburo tungsteno aseguran la sujeción firme y seguro de las agujas que evita la torsión de las cuales. Porta-agujas con insertos de carburo de tungsteno se reconocen por los anillos o mangos dorados.

Tutti i port'aghi con inserti in carburo di tungsteno “tucar” (tungsten-carbide) assicurano una presa dell'ago sicura e forte, che previene la torsione dall'ago stesso. I port'aghi con inserto in carburo di tungsteno sono riconoscibili per la doratura del manico o degli anelli.

0.5 mm

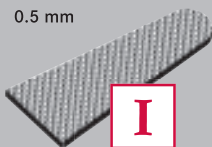

**I**

Normal für Nadeln und Nahtmaterial bis Stärke 4-0  
Regular for use with needles and sutures up to size 4-0

Normale pour aiguilles et matériel à suture jusqu'à l'épaisseur de 4-0  
Normal para agujas y material de suturar hasta el espesor de 4-0  
Normale per aghi e materiale per sutura fino ad uno spessore di 4-0

0.4 mm

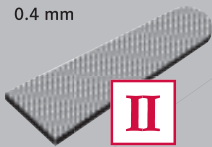

**II**

Fein für feine Nadeln und Nahtmaterial Stärke 5-0 + 6-0  
Fine for delicate needles and sutures sizes 5-0 + 6-0

Fino pour aiguilles fines et matériel à suture à l'épaisseur 5-0 + 6-0  
Fine para agujas finas y material de suturar espesores 5-0 + 6-0  
Fine per aghi fini e materiale per sutura con spessore 5-0 + 6-0

0.3 mm

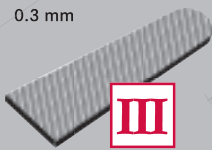

**III**

Extrafein für Mikro-Nadeln und Nahtmaterial Stärke 7-0 bis 10-0  
Extrafine for use with micro-needles and sutures size 7-0 and 10-0

Extrafino pour micro-aiguilles et matériel à suture à l'épaisseur 7-0 à 10-0  
Extrafine para micro-agujas y material de suturas espesor 7-0 y 10-0  
Extrafine per micro-aghi e materiale per sutura 7-0 e 10-0

Glatt für feine Nadeln und Nahtmaterial Stärke 7-0 bis 12-0  
Smooth for delicate needles and sutures sizes 7-0 and 12-0

Liso pour aiguilles fines et matériel à suture à l'épaisseur 7-0 à 12-0  
Lisse para agujas finas y material de suturas espesor 7-0 y 12-0  
Liscia per aghi fini e materiale per sutura 7-0 e 12-0

**IV**

Nadelhalter  
Needle holders

Porte-aiguilles  
Porta-agujas  
Porta-ghi

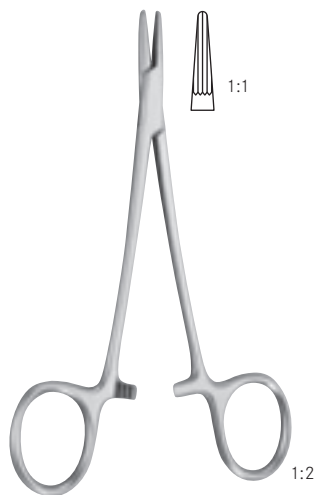

**DERF**  
**tk 20308-12**  
125 mm - 5"

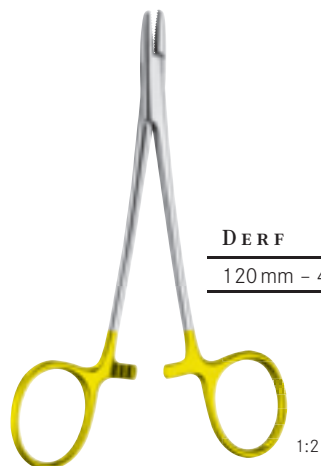

<b>DERF</b>		
120 mm - 4¾"	<b>tk 20008-12</b>	<b>tk 20508-12 TC</b>

ein Maul gefenstert  
*one fenestrated jaw*  
une coté du mors fenestré  
*un lado de la boca fenestrada*  
una parte del morso finestrado



**CRILE-MURRAY**  
**tk 20001-15**  
150 mm - 6"



<b>CRILE-WOOD</b>		
150 mm - 6"	<b>tk 20002-15</b>	<b>tk 20502-15 TC</b>
180 mm - 7"	<b>tk 20002-18</b>	<b>tk 20502-18 TC</b>
200 mm - 8"	<b>tk 20002-20</b>	<b>tk 20502-20 TC</b>

Nadelhalter  
Needle holders

Porte-aiguilles  
Porta-agujas  
Porta-ghi

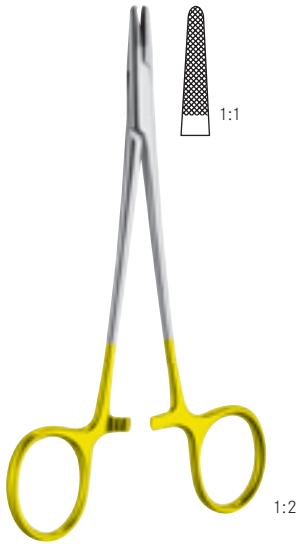

**HEGAR-BAUMGARTNER**

140 mm - 5 3/4"	<b>tk 20003-14</b>
140 mm - 5 3/4"	<b>tk 20503-14 TC</b>



**BABY-CRILE-WOOD**

<b>tk 20504-15 TC</b>
150 mm - 6"

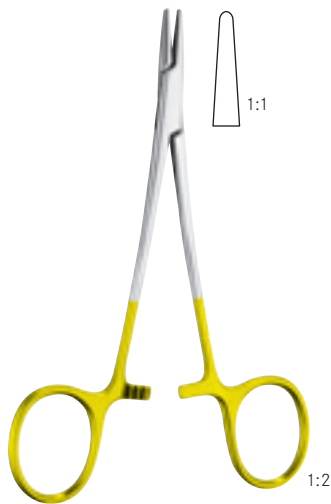

**WEBSTER**

130 mm - 5"	<b>tk 20009-13</b>
130 mm - 5"	<b>tk 20509-13 TC</b>

glatt  
smooth  
lisse  
liso  
liscio





**MATHIEU-OLSEN**

140 mm - 5 1/2"	<b>tk 20106-14</b>	<b>tk 20516-14 TC</b>
170 mm - 6 3/4"	<b>tk 20106-17</b>	<b>tk 20516-17 TC</b>
200 mm - 8"	<b>tk 20106-20</b>	<b>tk 20516-20 TC</b>

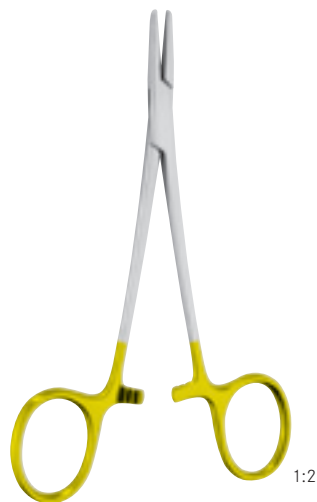

Nadelhalter  
Needle holders

Porte-aiguilles  
Porta-agujas  
Porta-agma



HALSEY	 1:1	 1:1
	130 mm - 5"	<b>tk 20010-13</b>
130 mm - 5"	<b>tk 20510-13 TC</b>	<b>tk 20511-13 TC</b>
	glatt <i>smooth</i> lisse <i>liso</i> liscio	gerieft <i>serrated</i> strié <i>estriada</i> zigrinato



OLSEN-HEGAR	 1:2	 1:2
	120 mm - 4¾"	<b>tk 20036-12</b>
140 mm - 5½"	<b>tk 20036-14</b>	<b>tk 20536-14 TC</b>
170 mm - 6¾"	<b>tk 20036-17</b>	<b>tk 20536-17 TC</b>
190 mm - 7½"	<b>tk 20036-19</b>	<b>tk 20536-19 TC</b>

Nadelhalter  
Needle holders

Porte-aiguilles  
Porta-agujas  
Porta-ghi



MAYO-HEGAR

<b>tk 20012-14</b>	<b>tk 20012-16</b>	<b>tk 20012-18</b>	<b>tk 20012-20</b>	<b>tk 20012-24</b>	<b>tk 20012-26</b>	<b>tk 20012-30</b>
140 mm - 5½"	160 mm - 6¼"	180 mm - 7"	200 mm - 8"	240 mm - 9½"	260 mm - 10¼"	300 mm - 12"

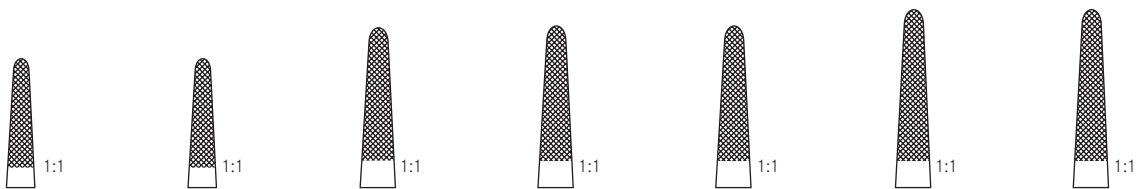

MAYO-HEGAR

<b>tk 20512-14 TC</b>	<b>tk 20512-16 TC</b>	<b>tk 20512-18 TC</b>	<b>tk 20512-20 TC</b>	<b>tk 20512-24 TC</b>	<b>tk 20512-26 TC</b>	<b>tk 20512-30 TC</b>
140 mm - 5½"	160 mm - 6¼"	180 mm - 7"	200 mm - 8"	240 mm - 9½"	260 mm - 10¼"	300 mm - 12"

Nadelhalter  
Needle holders

Porte-aiguilles  
Porta-agujas  
Porta-ghi



1:2

GILLIES

160 mm - 6 1/4"

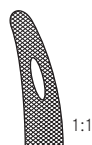

1:1



1:1

tk 20035-16

tk 20535-16 TC



1:2



1:2

GILLIES

145 mm - 5 3/4"



1:1



1:1

tk 20035-14

tk 20535-14 TC



1:2

FOSTER-GILLIES

120 mm - 4 3/4"



1:2



1:2



1:2



1:2

tk 20546-12 TC

tk 20547-12 TC

tk 20548-12 TC

tk 20549-12 TC

gerade, gerieft  
*straight, serrated*  
droit, strié  
*recta, estriada*  
rette, zigrinato

gerade, glatt  
*straight, smooth*  
droit, lisse  
*recta, lisa*  
rette, liscio

gebogen, gerieft  
*curved, serrated*  
courbe, strié  
*curva, estriada*  
curve, zigrinato

gebogen, glatt  
*curved, smooth*  
courbe, lisse  
*curva, lisa*  
curve, liscio

Nadelhalter  
Needle holders

Porte-aiguilles  
Porta-agujas  
Porta-ghi

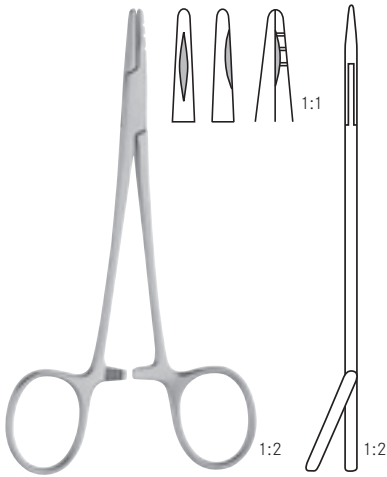

NEIVERT

**tk 20304-13**

125 mm - 5"

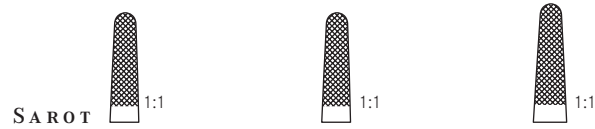

<b>tk 20524-18 TC</b>	<b>tk 20524-20 TC</b>	<b>tk 20524-26 TC</b>
180 mm - 7"	200 mm - 8"	260 mm - 10¼"

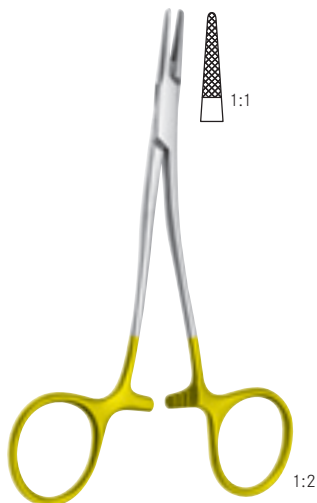

KILNER

**tk 20533-13 TC**

135 mm - 5¼"

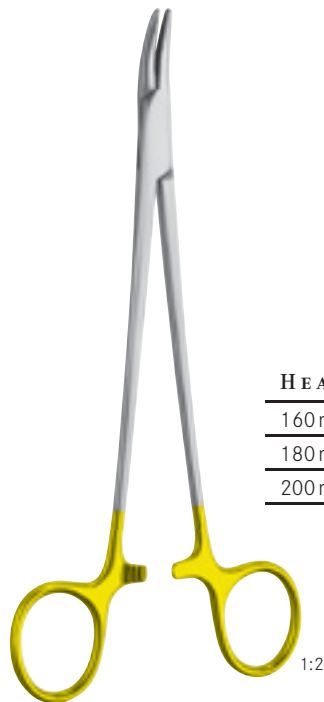

HEANEY

160 mm - 6¼"	<b>tk 20515-16 TC</b>
180 mm - 7"	<b>tk 20515-18 TC</b>
200 mm - 8"	<b>tk 20515-20 TC</b>

Nadelhalter  
Needle holders

Porte-aiguilles  
Porta-agujas  
Porta-agma

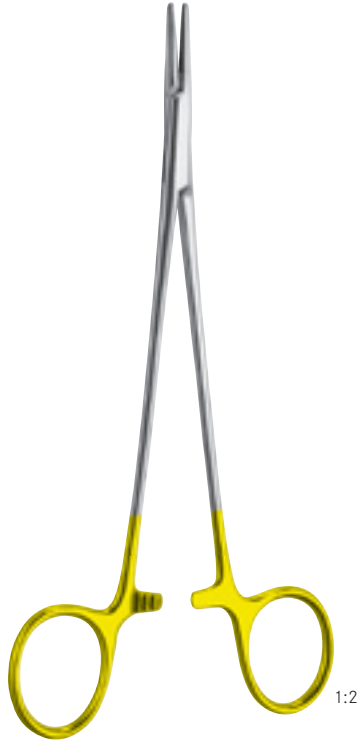

DE BAKEY

<b>tk 20522-18 TC</b>	<b>tk 20522-20 TC</b>	<b>tk 20522-23 TC</b>	<b>tk 20522-26 TC</b>
180 mm - 7"	170 mm - 6¾"	200 mm - 8"	240 mm - 9½"

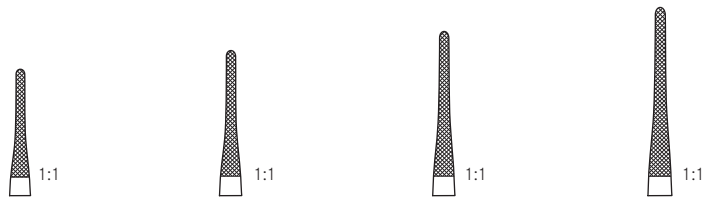

VASCULAR

<b>tk 20525-14 TC</b>	<b>tk 20525-18 TC</b>	<b>tk 20525-20 TC</b>	<b>tk 20525-23 TC</b>
140 mm - 5½"	180 mm - 7"	200 mm - 8"	230 mm - 9"



Nadelhalter  
Needle holders

Porte-aiguilles  
Porta-agujas  
Porta-ghi



<b>tk 20570-13</b>	<b>tk 20570-15</b>	<b>tk 20570-17</b>
130 mm - 5"	150 mm - 5¾"	170 mm - 6¾"

mit Spezialbeschichtung im Maul  
with special coated jaw

mors avec couche special  
boca con capa especial  
morso "diamant dust"

<b>tk 20570-18</b>	<b>tk 20570-20</b>	<b>tk 20570-23</b>
180 mm - 7"	200 mm - 8"	230 mm - 9"

mit Spezialbeschichtung im Maul  
with special coated jaw

mors avec couche special  
boca con capa especial  
morso "diamant dust"



RYDER			
	1:1	1:1	MINI-RYDER 1:1
130 mm - 5"	<b>tk 20540-13 TC</b>	<b>tk 20541-13</b>	<b>tk 20542-13 TC</b>
150 mm - 6"	<b>tk 20540-15 TC</b>	<b>tk 20541-15</b>	<b>tk 20542-15 TC</b>
180 mm - 7"	<b>tk 20540-18 TC</b>	<b>tk 20541-18</b>	<b>tk 20542-18 TC</b>
200 mm - 8"	<b>tk 20540-20 TC</b>	<b>tk 20541-20</b>	<b>tk 20542-20 TC</b>
230 mm - 9"	<b>tk 20540-23 TC</b>	<b>tk 20541-23</b>	<b>tk 20542-23 TC</b>
260 mm - 10¼"	<b>tk 20540-26 TC</b>		<b>tk 20542-26 TC</b>

mit Spezialbeschichtung im Maul  
with special coated jaw

Mors avec couche special  
Boca con capa especial  
Morso "diamant dust"

Nadelhalter  
Needle holders  
Porte-aiguilles  
Porta-agujas  
Porta-ghi



CASTROVIEJO-  
JACOBSON



140 mm - 5½"			tk 20210-14	tk 20710-14 TC
150 mm - 6"	tk 20204-15	tk 20704-15 TC	tk 20210-15	tk 20710-15 TC
180 mm - 7"	tk 20204-18	tk 20704-18 TC	tk 20210-18	tk 20710-18 TC
210 mm - 8¼"	tk 20204-21	tk 20704-21 TC	tk 20210-21	tk 20710-21 TC

glattes Maul  
*smooth jaws*

mors lisse

*boca lisa*

morso liscio

gerade, ohne Sperre  
*straight, without ratchet*

droit, sans crémaillère

*recta, sin cremallera*

retto, senza cremagliera

gerade, mit Sperre  
*straight, with ratchet*

droit, avec crémaillère

*recta, con cremallera*

retto, con cremagliera

1:2



140 mm - 5½"			tk 20211-14	tk 20711-14 TC
150 mm - 6"	tk 20205-15	tk 20705-15 TC	tk 20211-15	tk 20711-15 TC
180 mm - 7"	tk 20205-18	tk 20705-18 TC	tk 20211-18	tk 20711-18 TC
210 mm - 8¼"	tk 20205-21	tk 20705-21 TC	tk 20211-21	tk 20711-21 TC

glattes Maul  
*smooth jaws*

mors lisse

*boca lisa*

morso liscio

gebogen, ohne Sperre  
*curved, without ratchet*

courbe, sans crémaillère

*curva, sin cremallera*

curvo, senza cremagliera

gebogen, mit Sperre  
*curved, with ratchet*

courbe, avec crémaillère

*curva, con cremallera*

curvo, con cremagliera



BARRAQUER



145 mm - 5¾"	tk 20200-14	tk 20201-14
--------------	-------------	-------------

gerade  
*straight*

droit

*recta*

retto

gebogen  
*curved*

courbe

*curva*

curvo

1:2

Nadelhalter  
*Needle holders*

Porte-aiguilles  
*Porta-agujas*  
Porta-agma

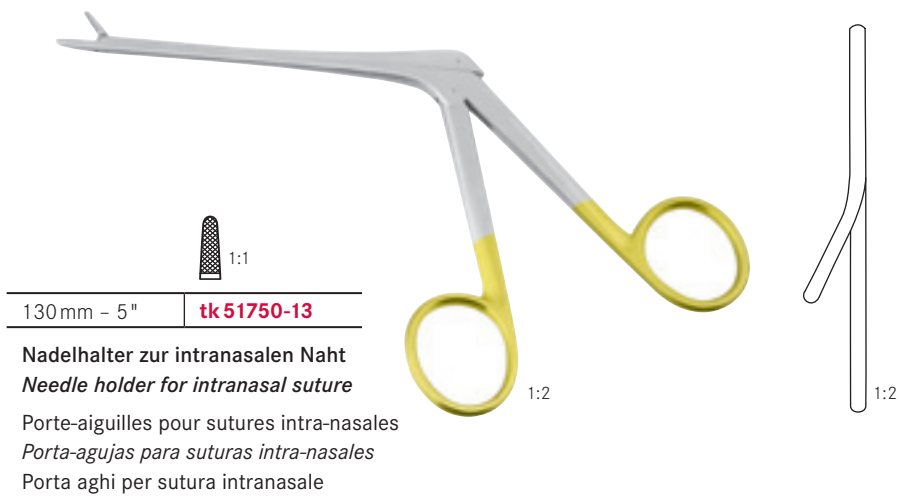

Nahtinstrumente  
Suture instruments

Instruments à suture  
Instrumental para sutura  
Strumenti per sutura



MOD. WIEN

235 mm - 9 1/4"

**tk 21375-23**

Fadenfänger  
*Ligature catcher*

Porte-ligature  
*Captador de hilos*  
Portalegature



BOZEMANN

210 mm - 8 1/4"

**tk 21380-21**

Schlingendreher  
*Knot tier*

Tords-fil  
*Tuerce-lazos*  
Torcifilo



230 mm - 9"

**tk 21385-23**

Fadengabel  
*Ligature adjuster*

Pousse-fil  
*Horquilla de hilos*  
Forchetta da sutura

Hämmer  
Mallets

Maillets  
Martillos  
Martelli



1:2

H A J E K

	27 mm Ø - 140 g
215 mm - 8½"	<b>tk 24047-21</b>

Stahl massiv  
*steel solid*  
acier solide  
*acero solido*  
acciaio massiccio



1:2

C O L L I N

	30 mm Ø - 220 g
200 mm - 8"	<b>tk 24051-20</b>

Stahl massiv  
*steel solid*  
acier solide  
*acero solido*  
acciaio massiccio

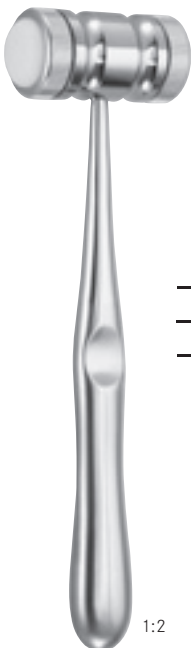

1:2

M E A D

	26 mm Ø - 320 g	26 mm Ø - 320 g
170 mm - 6¾"	<b>tk 24050-17</b>	<b>tk 24050-90</b>

Stahl massiv, mit Ferrozellbacken  
*steel solid, with Ferrozell faces*

acier solide, avec plaques en Ferrozell  
*acero solido, con placas en Ferrozell*  
acciaio massiccio, con punte di Ferrozell

Ersatzbacken, 1 Paar  
*spare faces, 1 pair*

plaques de rechange, 1 paire  
*placas de cambio, 1 par*  
placche di ricambio, 1 paia

Scharfe Doppellöffel  
*Bone currettes, double-ended*

Curettes doubles  
*Cucharillas de doble extremo*  
 Curette doppia

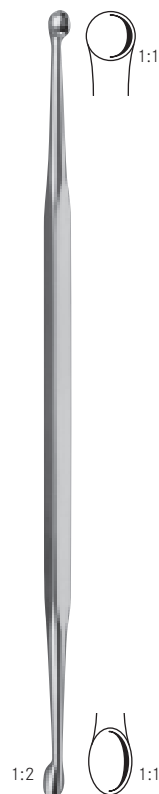
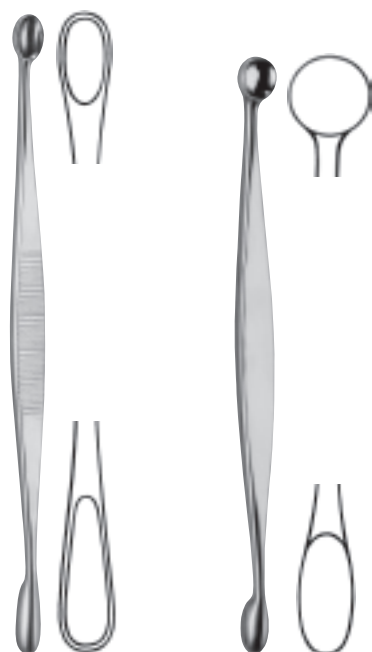

VOLKMANN

130 mm - 5"	<b>tk 24400-13</b>	<b>tk 24410-13</b>
140 mm - 5½"	<b>tk 24400-14</b>	
160 mm - 6¼"		<b>tk 24410-16</b>
170 mm - 6¾"	<b>tk 24400-17</b>	
200 mm - 8"		<b>tk 24410-20</b>

oval / oval  
*oval / oval*  
 ovale / ovale  
*ovalada / ovalada*  
 ovale / ovale

rund / oval  
*round / oval*  
 ronde / ovale  
*redonda / ovalada*  
 rotondo / ovale

210 mm - 8¼"  
**tk 24412-21**  
 rund / oval  
*round / oval*  
 ronde / ovale  
*redonda / ovalada*  
 rotondo / ovale

Raspatorien – Elevatorien  
*Periosteal raspatories – Elevators*

Rugines – Elevateurs  
*Raspatorios – Elevadores*  
 Periostotomi – Elevatori

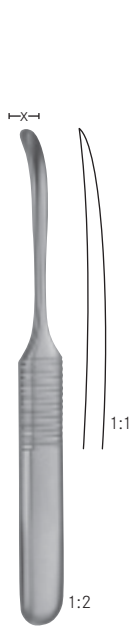

WILLIGER

	x = 5 mm
130 mm – 5"	<b>tk 24525-13</b>



WILLIGER

	160 mm – 6¼"
x = 4 mm	<b>tk 24525-16</b>
x = 6 mm	<b>tk 24526-16</b>



WILLIGER

	x = 5 mm	x = 6.5 mm
160 mm – 6¼"	<b>tk 24532-16</b>	<b>tk 24533-17</b>

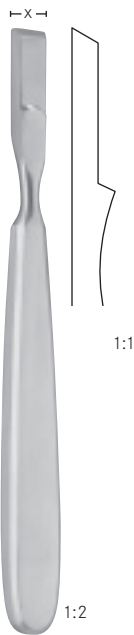

FARABEUF-  
 COLLIN

	x = 11 mm	x = 11 mm
160 mm – 6¼"	<b>tk 24528-01</b>	<b>tk 24528-02</b>

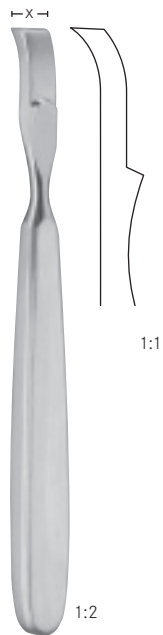

Raspatorien – Elevatorien  
*Periosteal raspatories – Elevators*

Rugines – Elevateurs  
*Raspatorios – Elevadores*  
 Periostotomi – Elevatori

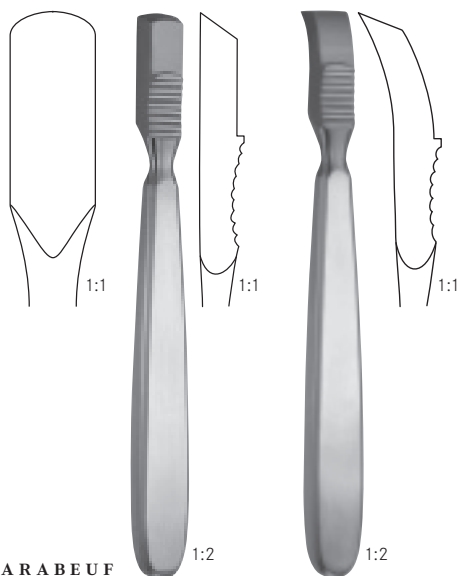

FARABEU F	
150 mm - 6"	<b>tk 24520-15</b> <b>tk 24521-15</b>
gerade <i>straight</i>	gebogen <i>curved</i>
droit <i>recta</i>	courbe <i>curva</i>
retto	curvo

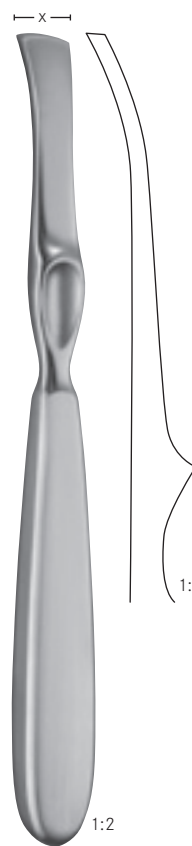

LAMBOTTE	
	210 mm - 8¼"
x = 5 mm	<b>tk 24523-05</b>
x = 10 mm	<b>tk 24523-10</b>
x = 15 mm	<b>tk 24523-15</b>
x = 20 mm	<b>tk 24523-20</b>
x = 25 mm	<b>tk 24523-25</b>



ADSON

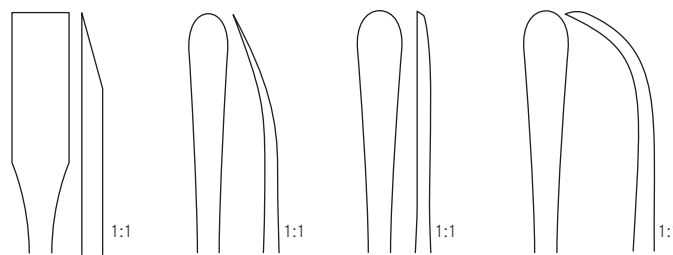

	Fig. 1	Fig. 2	Fig. 3	Fig. 4
170 mm - 6¾"	<b>tk 24535-01</b>	<b>tk 24535-02</b>	<b>tk 24535-03</b>	<b>tk 24535-04</b>



Septum - Elevatorien  
*Septum elevators*

Elevateurs pour la cloison nasale  
*Elevadores para el tabique nasal*  
Elevatori per setto



**COTTLE**

**tk 51607-19**

190 mm - 7½"

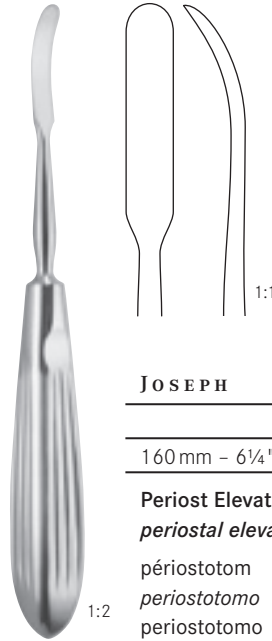

**JOSEPH**

4 mm

160 mm - 6¼"

**tk 51613-16**

**Periost Elevatorien**  
*periostal elevators*

périostotom  
*periostotomo*  
periostotomo



**HALLE**

**tk 51617-16**

160 mm - 6¼"

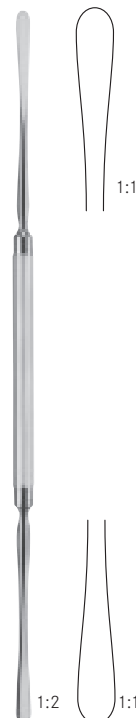

**BALLENGER-HAJEK**

190 mm - 7½"

**tk 51637-19**

220 mm - 8¾"

**tk 51637-22**

Septum - Elevatorien  
Septum elevators

Elevateurs pour la cloison nasale  
Elevadores para el tabique nasal  
Elevatori per setto



FREER

**tk 51625-19**

190 mm - 7½"

stumpf  
blunt

mousse  
roma  
smussa

1:2

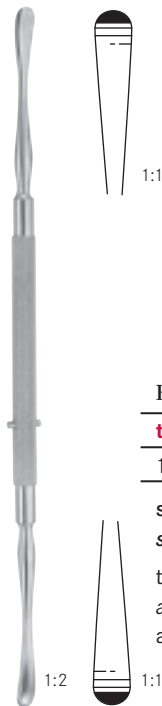

FREER

**tk 51627-18**

180 mm - 7"

scharf/stumpf  
sharp/blunt

tranchant/mousse  
aguda/roma  
acuta/smussa

1:2

1:1



COTTLE



1:1

2.5 mm

160 mm - 6¼"









**tk 51646-02**

1:2

Bohrer  
Burrs







Fraises  
Brocas  
Frese









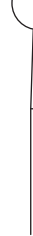

DIAMANT-BOHRER	 1:1	 1:1	 1:1	 1:1	 1:1	 1:1	 1:1	 1:1
	0.6 mm Ø	0.7 mm Ø	0.8 mm Ø	1.0 mm Ø	1.5 mm Ø	1.8 mm Ø	2.3 mm Ø	2.7 mm Ø
70 mm - 2¾"	tk 52810-06	tk 52810-07	tk 52810-08	tk 52810-10	tk 52810-15	tk 52810-18	tk 52810-23	tk 52810-27

Diamantbohrer, 70 mm lang, Schaft-Ø 2.35 mm  
 Diamond dust polishing burrs, 70 mm long, shank diameter 2.35 mm

Fraises à polir, diamantées, 70 mm de long, Ø de tige 2.35 mm  
 Brocas diamantadas, largo 70 mm, vástago-Ø 2.35 mm  
 Frese diamantate, 70 mm lungo, asta Ø 2.35 mm



	 1:1	 1:1	 1:1	 1:1	 1:1	 1:1	 1:1
	3.0 mm Ø	3.5 mm Ø	4.0 mm Ø	4.5 mm Ø	5.0 mm Ø	6.0 mm Ø	7.0 mm Ø
70 mm - 2¾"	tk 52810-30	tk 52810-35	tk 52810-40	tk 52810-45	tk 52810-50	tk 52810-60	tk 52810-70



DIAMANT-BOHRER	 1:1	 1:1	 1:1	 1:1	 1:1	 1:1	 1:1	 1:1
	1.5 mm Ø	1.8 mm Ø	2.3 mm Ø	2.7 mm Ø	3.0 mm Ø	3.5 mm Ø	4.0 mm Ø	4.5 mm Ø
95 mm - 3¾"	tk 52812-15	tk 52812-18	tk 52812-23	tk 52812-27	tk 52812-30	tk 52812-35	tk 52812-40	tk 52812-45

Diamantbohrer, 95 mm lang, Schaft-Ø 2.35 mm  
 Diamond dust polishing burrs, 95 mm long, shank diameter 2.35 mm

Fraises à polir, diamantées, 95 mm de long, Ø de tige 2.35 mm  
 Brocas diamantadas, largo 95 mm, vástago-Ø 2.35 mm  
 Frese diamantate, 95 mm lungo, asta Ø 2.35 mm

	 1:1	 1:1	 1:1
	5.0 mm Ø	6.0 mm Ø	7.0 mm Ø
95 mm - 3¾"	tk 52812-50	tk 52812-60	tk 52812-70

Bohrer | Fraises  
 Burrs | Brocas  
 Frese

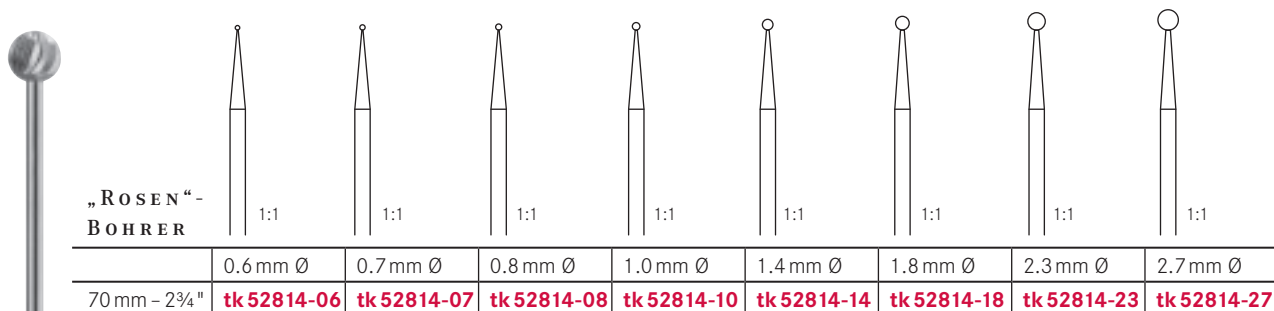

	0.6 mm Ø	0.7 mm Ø	0.8 mm Ø	1.0 mm Ø	1.4 mm Ø	1.8 mm Ø	2.3 mm Ø	2.7 mm Ø
70 mm - 2¾"	<b>tk 52814-06</b>	<b>tk 52814-07</b>	<b>tk 52814-08</b>	<b>tk 52814-10</b>	<b>tk 52814-14</b>	<b>tk 52814-18</b>	<b>tk 52814-23</b>	<b>tk 52814-27</b>

„ROSEN“-Bohrer, 70 mm lang, Schaft-Ø 2.35 mm, rostfrei  
 “Rosen” burrs, 70 mm long, shank diameter 2.35 mm, stainless  
 Fraises de «Rosen», 70 mm de long, Ø de tige 2.35 mm, inoxydables  
 Brocas “Rosen”, largo 70 mm, vástago-Ø 2.35 mm, inoxidable  
 Frese “Rosen”, 70 mm lungo, asta Ø 2.35 mm, inossidabile

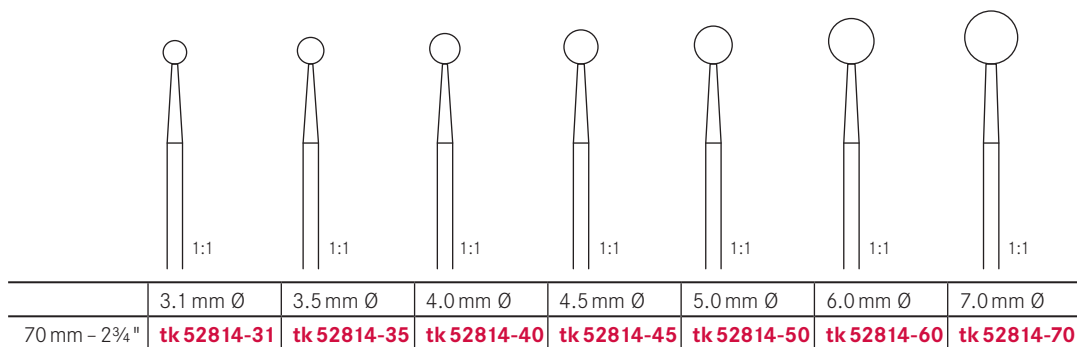

	3.1 mm Ø	3.5 mm Ø	4.0 mm Ø	4.5 mm Ø	5.0 mm Ø	6.0 mm Ø	7.0 mm Ø
70 mm - 2¾"	<b>tk 52814-31</b>	<b>tk 52814-35</b>	<b>tk 52814-40</b>	<b>tk 52814-45</b>	<b>tk 52814-50</b>	<b>tk 52814-60</b>	<b>tk 52814-70</b>

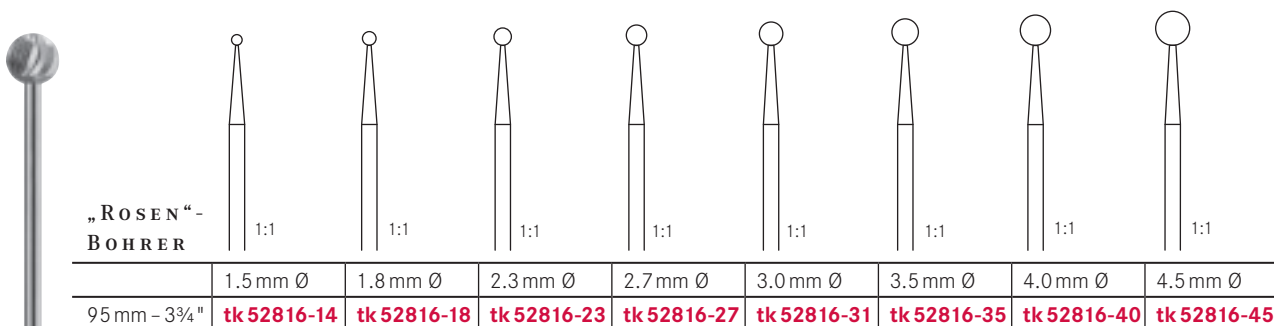

	1.5 mm Ø	1.8 mm Ø	2.3 mm Ø	2.7 mm Ø	3.0 mm Ø	3.5 mm Ø	4.0 mm Ø	4.5 mm Ø
95 mm - 3¾"	<b>tk 52816-14</b>	<b>tk 52816-18</b>	<b>tk 52816-23</b>	<b>tk 52816-27</b>	<b>tk 52816-31</b>	<b>tk 52816-35</b>	<b>tk 52816-40</b>	<b>tk 52816-45</b>

„ROSEN“-Bohrer, 95 mm lang, Schaft-Ø 2.35 mm, rostfrei  
 “Rosen” burrs, 95 mm long, shank diameter 2.35 mm, stainless  
 Fraises de «Rosen», 95 mm de long, Ø de tige 2.35 mm, inoxydables  
 Brocas “Rosen”, largo 95 mm, vástago-Ø 2.35 mm, inoxidable  
 Frese “Rosen”, 95 mm lungo, asta Ø 2.35 mm, inossidabile

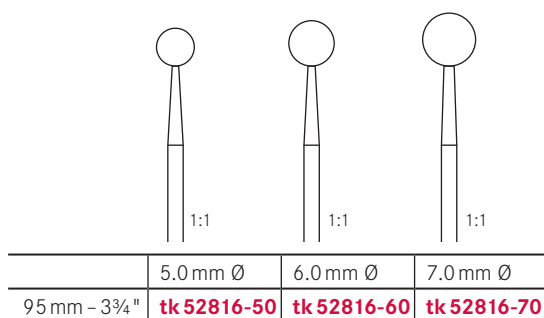

	5.0 mm Ø	6.0 mm Ø	7.0 mm Ø
95 mm - 3¾"	<b>tk 52816-50</b>	<b>tk 52816-60</b>	<b>tk 52816-70</b>

Bohrer  
Burrs

Fraises  
Brocas  
Frese



„ROSEN“- BOHRER TC	1:1	1:1	1:1	1:1	1:1	1:1	1:1
	0.6 mm Ø	0.8 mm Ø	1.0 mm Ø	1.4 mm Ø	1.8 mm Ø	2.3 mm Ø	2.7 mm Ø
70 mm - 2¾"	tk 49965-06	tk 49965-08	tk 49965-10	tk 49965-14	tk 49965-18	tk 49965-23	tk 49965-27

„Rosen“-Bohrer, 70 mm lang, Schaft-Ø 2.35 mm, TC  
 “Rosen” burrs, 70 mm long, shank diameter 2.35 mm, TC  
 Fraises de «Rosen», 70 mm de long, Ø de tige 2.35 mm, TC  
 Brocas “Rosen”, largo 70 mm, vástago-Ø 2.35 mm, TC  
 Frese “Rosen”, 70 mm lungo, asta Ø 2.35 mm, TC

	1:1	1:1	1:1	1:1	1:1	1:1	1:1
	3.1 mm Ø	3.5 mm Ø	4.0 mm Ø	4.5 mm Ø	5.0 mm Ø	6.0 mm Ø	7.0 mm Ø
70 mm - 2¾"	tk 49965-31	tk 49965-35	tk 49965-40	tk 49965-45	tk 49965-50	tk 49965-60	tk 49965-70



Andere Modelle und Längen sowie Imperatorbohrer auf Anfrage erhältlich

Other models and lengths as well as imperator drills on request

Autres modèles et longueurs ainsi que des fraises “imperator” sont disponibles sur demande

Otros modelos y longitudes y brocas “imperator” son disponibles según demanda

Altri modelli e lunghezze così come modell “imperatore” disponibili su richiesta



tk 56795-00

Bohrständer für 24 Bohrer  
Drillcarrier for 24 drills

Support pour 24 mèches

Soporte para 24 brocas

Supporto per zu punte

Hohlmeißelzangen  
Bone rongeurs

Pince gouges  
Pinzas gubias  
Pinze sgorbie



MINI-  
FRIEDMAN

**tk 24605-12**

120 mm - 4¾"

1:2



FRIEDMAN

**tk 24605-14**

140 mm - 5½"

1:2



1:2

BLUMENTHAL



1:1

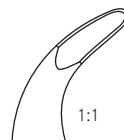

1:1



1:1

	Fig. 1	Fig. 2	Fig. 3
155 mm - 6"	<b>tk 24606-01</b>	<b>tk 24606-02</b>	<b>tk 24606-03</b>

Hohlmeißelzangen  
*Bone rongeurs*

Pince gouges  
*Pinzas gubias*  
Pinze sgorbie



BÖHLER		
150 mm - 6"	<b>tk 24613-00</b>	<b>tk 24613-02</b>

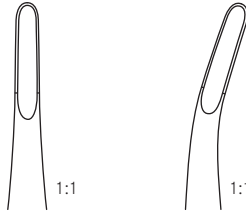

ZAUFAL-JANSEN
<b>tk 24614-18</b>
180 mm - 7"

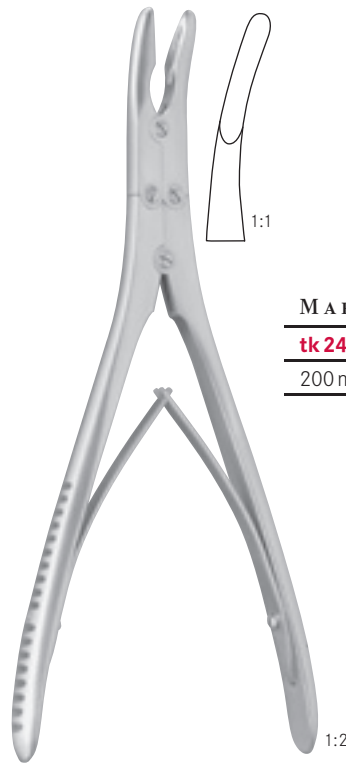

MARQUARDT
<b>tk 24614-20</b>
200 mm - 8"



Hohlmeißelzangen  
Bone rongeurs

Pince gouges  
Pinzas gubias  
Pinze sgorbie



**BEYER**

**tk 24615-18**

180mm - 7"



**RUSKIN**

180mm - 7"

**tk 24616-05**

**tk 24616-04**



Knochensplitterzangen  
Bone cutting forceps

Pinces coupantes à os  
Pinzas cortantes para huesos  
Cesoie per ossa

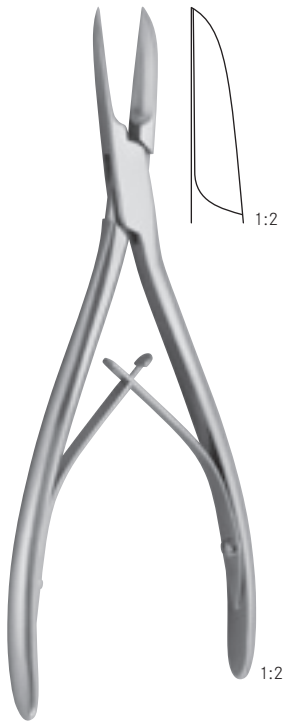

COTTLE-  
KAZANJIAN

**tk 24649-19**

190mm - 7½"



BÖHLER

150mm - 6"

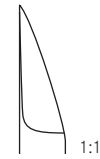

1:1

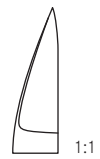

1:1

gerade  
*straight*  
droit  
*recta*  
rette

gebogen  
*curved*  
courbe  
*curva*  
curve

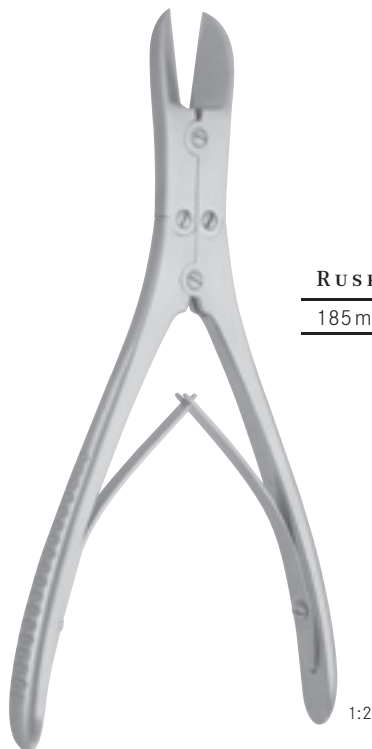

RUSKIN-LISTON

185mm - 7¼"

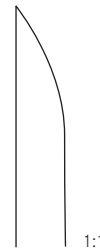

1:1



1:1

gerade  
*straight*  
droit  
*recta*  
rette

gebogen  
*curved*  
courbe  
*curva*  
curve

Mikro-Präparierscheren  
 Micro dissecting scissors

Micro ciseaux à dissection  
 Micro tijeras de disección  
 Forbici per micro chirurgia

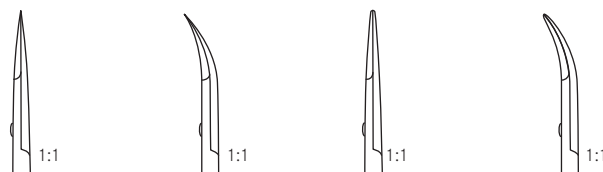

145 mm - 5¾"	<b>tk 25602-01</b>	<b>tk 25603-01</b>	<b>tk 25602-02</b>	<b>tk 25603-02</b>
180 mm - 7"	<b>tk 25610-01</b>	<b>tk 25611-01</b>	<b>tk 25610-02</b>	<b>tk 25611-02</b>

kurze Schneide 8 mm, glatt  
 short blades 8 mm, smooth  
 lames courtes 8 mm, lisses  
 hojas cortas 8 mm, lisos  
 lama corta 8 mm, liscia

gerade, spitz  
 straight, sharp  
 droites, pointues  
 rectas, agudas  
 retta, acuta

gebogen, spitz  
 curved, sharp  
 courbes, pointues  
 curvas, agudas  
 curva, acuta

gerade, stumpf  
 straight, blunt  
 droites, mousses  
 rectas, romas  
 retta, smussa

gebogen, stumpf  
 curved, blunt  
 courbes, mousses  
 curvas, romas  
 curva, smussa

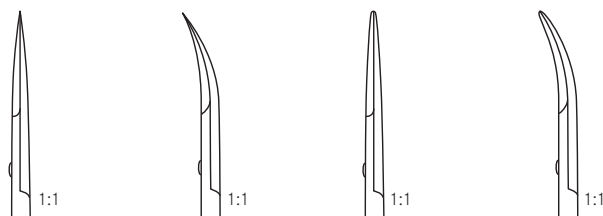

145 mm - 5¾"	<b>tk 25602-03</b>	<b>tk 25603-03</b>	<b>tk 25602-04</b>	<b>tk 25603-04</b>
180 mm - 7"	<b>tk 25610-03</b>	<b>tk 25611-03</b>	<b>tk 25610-04</b>	<b>tk 25611-04</b>

lange Schneide 14 mm, glatt  
 long blades 14 mm, smooth  
 lames longues 14 mm, lisses  
 hojas largas 14 mm, lisos  
 lama lunga 14 mm, liscia

gerade, spitz  
 straight, sharp  
 droites, pointues  
 rectas, agudas  
 retta, acuta

gebogen, spitz  
 curved, sharp  
 courbes, pointues  
 curvas, agudas  
 curva, acuta

gerade, stumpf  
 straight, blunt  
 droites, mousses  
 rectas, romas  
 retta, smussa

gebogen, stumpf  
 curved, blunt  
 courbes, mousses  
 curvas, romas  
 curva, smussa

Mikropinzetten  
Micro forceps

Micro pincers  
Micro pinzas  
Pinze per microchirurgia

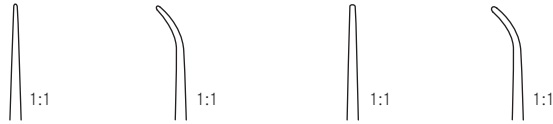

8 mm Ø	0.3 mm	0.3 mm	0.7 mm	0.7 mm
150 mm - 6"	<b>tk 25686-01</b>	<b>tk 25686-02</b>	<b>tk 25686-03</b>	<b>tk 25686-04</b>
180 mm - 7"	<b>tk 25687-01</b>	<b>tk 25687-02</b>	<b>tk 25687-03</b>	<b>tk 25687-04</b>
210 mm - 8¼"	<b>tk 25688-01</b>	<b>tk 25688-02</b>	<b>tk 25688-03</b>	<b>tk 25688-04</b>
230 mm - 9"	<b>tk 25689-01</b>	<b>tk 25689-02</b>	<b>tk 25689-03</b>	<b>tk 25689-04</b>

Maul glatt  
Jaw smooth  
Mors lisse  
Boca lisa  
Morso liscio

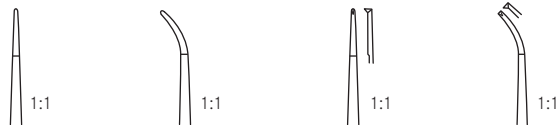
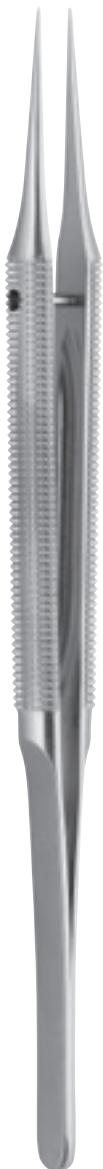

8 mm Ø	0.3 mm	0.3 mm	0.7 mm	0.7 mm
150 mm - 6"	<b>tk 25686-05</b>	<b>tk 25686-06</b>	<b>tk 25686-09</b>	<b>tk 25686-10</b>
180 mm - 7"	<b>tk 25687-05</b>	<b>tk 25687-06</b>	<b>tk 25687-09</b>	<b>tk 25687-10</b>
210 mm - 8¼"	<b>tk 25688-05</b>	<b>tk 25688-06</b>	<b>tk 25688-09</b>	<b>tk 25688-10</b>
230 mm - 9"	<b>tk 25689-05</b>	<b>tk 25689-06</b>	<b>tk 25689-09</b>	<b>tk 25689-10</b>

Fadenplatte 6,0 mm x 0,3 mm, glatt  
Tying platform 6.0 mm x 0.3 mm, smooth  
Plate-forme 6.0 mm x 0.3 mm, lisse  
Plataforma 6.0 mm x 0.3 mm, lisa  
Piano per sutura 6.0 mm x 0.3 mm, liscio

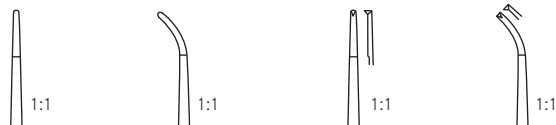

8 mm Ø	0.3 mm	0.3 mm	0.7 mm	0.7 mm
150 mm - 6"	<b>tk 25686-07</b>	<b>tk 25686-08</b>	<b>tk 25686-11</b>	<b>tk 25686-12</b>
180 mm - 7"	<b>tk 25687-07</b>	<b>tk 25687-08</b>	<b>tk 25687-11</b>	<b>tk 25687-12</b>
210 mm - 8¼"	<b>tk 25688-07</b>	<b>tk 25688-08</b>	<b>tk 25688-11</b>	<b>tk 25688-12</b>
230 mm - 9"	<b>tk 25689-07</b>	<b>tk 25689-08</b>	<b>tk 25689-11</b>	<b>tk 25689-12</b>

Fadenplatte 6,0 mm x 0,7 mm, glatt  
Tying platform 6.0 mm x 0.7 mm, smooth  
Plate-forme 6.0 mm x 0.7 mm, lisse  
Plataforma 6.0 mm x 0.7 mm, lisa  
Piano per sutura 6.0 mm x 0.7 mm, liscio

**Mikronadelhalter mit Rundgriff**  
*Micro needle holders with round handle*

Micro porte aiguilles avec manche ronde  
*Micro porta agujas con mango redondo*  
 Micro porta aghi con manico rotondo



110 mm - 4 1/4"	8 mm Ø	<b>tk 25637-11</b>	<b>tk 25638-11</b>
125 mm - 5"	7 mm Ø	<b>tk 25654-12</b>	<b>tk 25655-12</b>
130 mm - 5"	8 mm Ø	<b>tk 25658-13</b>	<b>tk 25659-13</b>
130 mm - 5"	10 mm Ø	<b>tk 25652-13</b>	<b>tk 25653-13</b>
150 mm - 6"	8 mm Ø	<b>tk 25640-15</b>	<b>tk 25641-15</b>
180 mm - 7"	8 mm Ø	<b>tk 25664-18</b>	<b>tk 25665-18</b>
180 mm - 7"	10 mm Ø	<b>tk 25668-18</b>	<b>tk 25669-18</b>

ohne Sperre  
*without ratchet*  
 sans crémaillère  
*sin cremallera*  
 senza cremagliera

gerade  
*straight*

gebogen  
*curved*

droit  
*recta*  
 retto

courbe  
*curva*  
 curvo

110 mm - 4 1/4"	8 mm Ø	<b>tk 25635-11</b>	<b>tk 25636-11</b>
125 mm - 5"	7 mm Ø	<b>tk 25656-12</b>	<b>tk 25657-12</b>
130 mm - 5"	8 mm Ø	<b>tk 25662-13</b>	<b>tk 25663-13</b>
130 mm - 5"	10 mm Ø	<b>tk 25645-13</b>	<b>tk 25646-13</b>
150 mm - 6"	8 mm Ø	<b>tk 25642-15</b>	<b>tk 25643-15</b>
180 mm - 7"	8 mm Ø	<b>tk 25666-18</b>	<b>tk 25667-18</b>
180 mm - 7"	10 mm Ø	<b>tk 25670-18</b>	<b>tk 25671-18</b>

mit Sperre  
*with ratchet*  
 avec crémaillère  
*con cremallera*  
 con cremagliera

gerade  
*straight*

gebogen  
*curved*

droit  
*recta*  
 retto

courbe  
*curva*  
 curvo

Mikro-Federscheren  
Micro-scissors

Micro ciseaux à ressorts  
Micro tijeras con resorte  
Forbici per microchirurgia

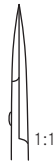
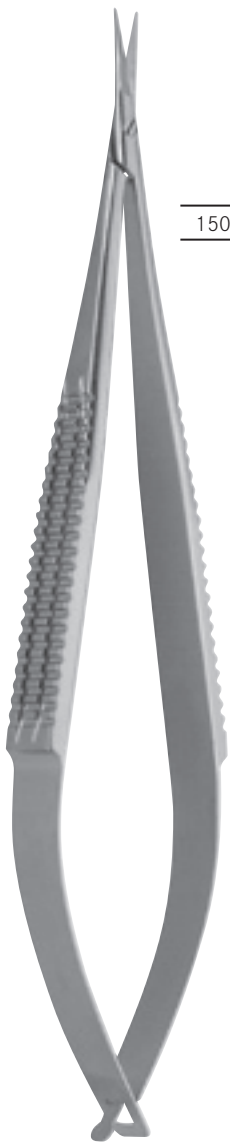

150 mm - 6"

**tk 25670-15**

gerade, kurze Schneide  
*straight, short blades*  
droites, lames courtes  
*recta, hojas cortas*  
retta, lama corta

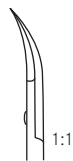

**tk 25671-15**

gebogen, kurze Schneide  
*curved, short blades*  
courbes, lames courtes  
*curva, hojas cortas*  
curva, lama corta



**tk 25672-15**

gerade, lange Schneide  
*straight, long blades*  
droites, lames longues  
*recta, hojas largas*  
retta, lama lunga

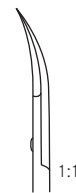

**tk 25673-15**

gebogen, lange Schneide  
*curved, long blades*  
courbes, lames longues  
*curva, hojas largas*  
curva, lama lunga

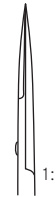

150 mm - 6"

**tk 25678-15**

gerade, gezahnt  
*straight, saw edge*  
droites, dentelés  
*recta, dentadas*  
retta, dentata

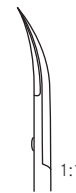

**tk 25679-15**

gebogen, gezahnt  
*curved, saw edge*  
courbes, dentelés  
*curva, dentadas*  
curva, dentata

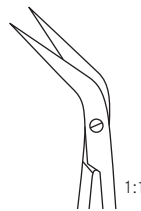

150 mm - 6"

**tk 25675-15**

180 mm - 7"

**tk 25677-18**

kniegebogen, 45°  
*angled on flat, 45°*  
angulaires, 45°  
*acodada, 45°*  
angolata, 45°

Mikro-Knüpppinzetten  
*Micro suture tying forceps*

Micro pinces pour sutures  
*Micro pinzas para suturas*  
 Pinze per micro-suture

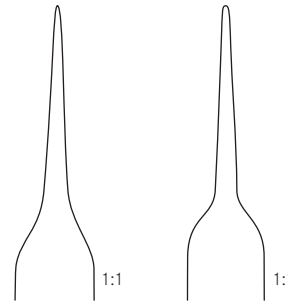





LAZAR	0.5 mm	0.8 mm
155 mm - 6"	<b>tk 26016-01</b>	<b>tk 26016-02</b>

Mikronadelhalter  
Micro needle holders

Micro porte aiguilles  
Micro porta agujas  
Micro porta aghi



JACOBSON	 1:1	 1:1	 1:1	 1:1
	x = 1 mm	x = 1 mm	x = 1 mm	x = 1 mm
180 mm - 7"	<b>tk 25740-01</b>	<b>tk 25740-02</b>	<b>tk 25740-13</b>	<b>tk 25740-14</b>
ohne Sperre without ratchet	gerade straight	gebogen curved	gerade, diamantiert straight, diamond coated	gebogen, diamantiert curved, diamond coated
sans crémaillère sin cremallera senza cremagliera	droit recta retto	courbe curva curvo	droit, diamanté recta, diamantada retto, diamantato	courbe, diamanté curva, diamantada curvo, diamantato
	x = 1 mm	x = 1 mm	x = 1 mm	x = 1 mm
180 mm - 7"	<b>tk 25740-03</b>	<b>tk 25740-04</b>	<b>tk 25740-15</b>	<b>tk 25740-16</b>
mit Sperre with ratchet	gerade straight	gebogen curved	gerade, diamantiert straight, diamond coated	gebogen, diamantiert curved, diamond coated
avec crémaillère con cremallera con cremagliera	droit recta retto	courbe curva curvo	droit, diamanté recta, diamantada retto, diamantato	courbe, diamanté curva, diamantada curvo, diamantato
	x = 1 mm	x = 1 mm	x = 1 mm	x = 1 mm
180 mm - 7"	<b>tk 25740-05 tucar</b>	<b>tk 25740-06 tucar</b>	<b>tk 25740-09 tucar</b>	<b>tk 25740-10 tucar</b>
ohne Sperre without ratchet	gerade, glatt straight, smooth	gebogen, glatt curved, smooth	gerade, gerieft straight, serrated	gebogen, gerieft curved, serrated
sans crémaillère sin cremallera senza cremagliera	droit, lisse recta, liso retto, liscio	courbe, lisse curva, lisa curvo, liscio	droit, strié recta, estriada retto, zigrinato	courbe, strié curva, estriada curvo, zigrinato
	x = 1 mm	x = 1 mm	x = 1 mm	x = 1 mm
180 mm - 7"	<b>tk 25740-07 tucar</b>	<b>tk 25740-08 tucar</b>	<b>tk 25740-11 tucar</b>	<b>tk 25740-12 tucar</b>
mit Sperre with ratchet	gerade, glatt straight, smooth	gebogen, glatt curved, smooth	gerade, gerieft straight, serrated	gebogen, gerieft curved, serrated
avec crémaillère con cremallera con cremagliera	droit, lisse recta, liso retto, liscio	courbe, lisse curva, lisa curvo, liscio	droit, strié recta, estriada retto, zigrinato	courbe, strié curva, estriada curvo, zigrinato



**Instrumenten-Kassetten aus Edelstahl**  
*Instrument trays made of stainless steel*

Contenaires d'instruments en acier inox  
*Caja para instrumental en acero inox*  
Scatole per sterilizzazione di acciaio inossidabile

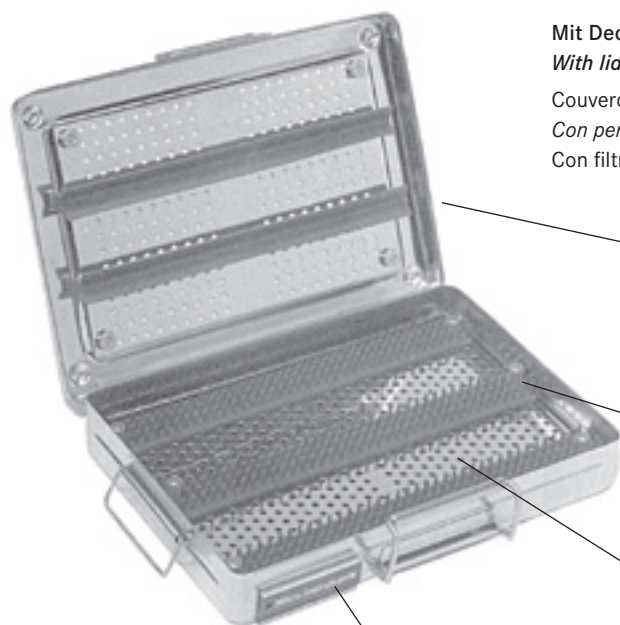

Mit Deckel- und Bodenlochung mit Textil-Langzeitfiltern für Dampfsterilisation  
*With lid and bottom perforation with textil "Longterm" filters for steam sterilisation*  
Couvercle et boîtier perforé avec filtre en textile pour stérilisation à vapeur  
*Con perforación en tapa y fondo, con filtros en tejido para esterilización a vapor*  
Con filtri tessili, per la sterilizzazione a vapore

Silikon-Andrückleisten zum Fixieren der Instrumente  
*Silicone protective strips for fixation of instruments*

Tapis en silicone pour fixer les instruments  
*Tiras de silicon para fijar los instrumentos*  
Strisce di silicone per fissare gli strumenti

Silikon-Noppenstreifen zur schonenden Auflage der Instrumente  
*Silicon strips for a soft and protective storage of the instruments*

Tapis en silicone pour la protection des instruments  
*Matas de silicon para proteger los instrumentos*  
Stuoie di silicone per proteggere gli strumenti

1 herausnehmbare Siebplatte  
*1 removable tray insert*

1 tableau pour sortir  
*1 placa para sacar*  
1 cestello

Kennzeichnungsschilder nach Wahl (Farbe und Text)  
*Marking plate for selection: colour and description*

Plaquette d'identification (texte et couleur selon demande)  
*Placas de identificación a opción (color y texto)*  
Placche d'identificazione (colore a scelta)

280x195x55 mm	265x255x55 mm	380x260x55 mm	200x140x55 mm	470x250x55 mm
<b>tk 85100-01</b>	<b>tk 85101-01</b>	<b>tk 85102-01</b>	<b>tk 85103-01</b>	<b>tk 85104-01</b>

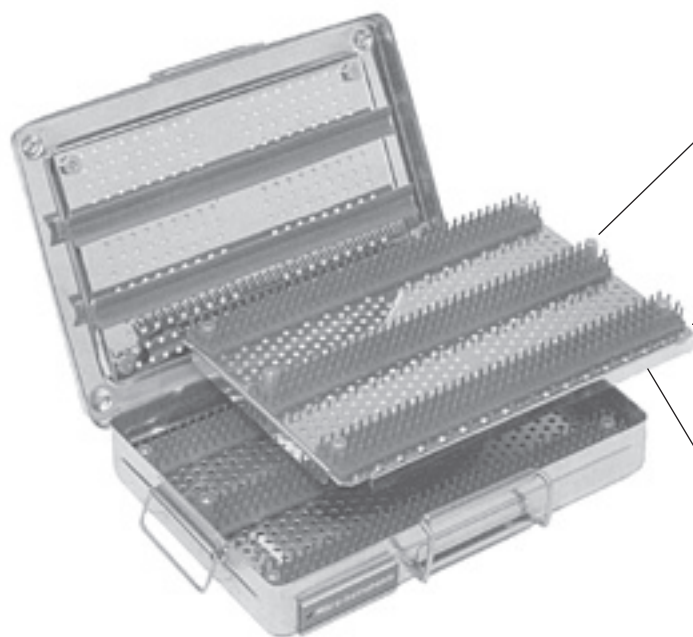

wärmeisolierende Halteknöpfe zum Herausheben  
*heatisolated handles*

pins isolés pour sortir des tableaux  
*pernos aislados para sacar las placas*  
maniglia a forma di botone

2 herausnehmbare Siebplatten  
*2 removable tray inserts*

2 tableaux detachables  
*2 placas para sacar*  
2 cestelli

Silikon-Andrückleisten an der Unterseite des Siebes  
*Silicone protective strips at the lower side of the tray*

Tapis de silicone à la partie inférieure des tableaux  
*Tiras de silicon a bajo de las placas*  
Strisce di silicone sulla parte inferiore dell'inserto

280x195x65 mm	265x255x65 mm	380x260x65 mm	200x140x65 mm	470x250x65 mm
<b>tk 85100-03</b>	<b>tk 85101-03</b>	<b>tk 85102-03</b>	<b>tk 85103-03</b>	<b>tk 85104-03</b>



**Verschiedene Behälter**  
*Different containers*

 Boîtes diverses  
 Contenedores varios  
 Vassoi diversi

30 mm Ø x 90 mm	<b>tk 83142-08</b>
50 mm Ø x 100 mm	<b>tk 83142-11</b>
50 mm Ø x 130 mm	<b>tk 83142-12</b>
50 mm Ø x 175 mm	<b>tk 83142-16</b>
75 mm Ø x 100 mm	<b>tk 83143-14</b>
75 mm Ø x 130 mm	<b>tk 83143-17</b>
75 mm Ø x 200 mm	<b>tk 83143-20</b>

18/8 rostfrei, Standgefäße, ohne Deckel  
 18/8 stainless steel, mugs, without cover  
 18/8 inoxydable, boîtiers, sans couvercle  
 18/8 inoxidable, cilindros sin tapa  
 18/8 inossidabile, recipienti cilindrici



95 mm Ø x 60 mm	<b>tk 83160-90</b>
-----------------	--------------------

Sputumbecher, matt, 18/8 rostfrei  
 Sputum mugs, tarnished, 18/8 stainless steel

Coupoles, depoli, 18/8 inoxydable  
 Escupideras, mate, 18/8 inoxidable  
 Sputacchiera, 18/8 inossidabile



0,05l	50 mm Ø x 50 mm	<b>tk 83155-50</b>
-------	-----------------	--------------------

Medizinbecher, graduert, matt, 18/8 rostfrei  
 Medicine cup, graduated, tarnished, 18/8 stainless steel  
 Timbale, graduée, depolie, 18/8 inoxydable  
 Vaso, graduado, mate, 18/8 inoxidable  
 Recipiente, graduato, 18/8 inossidabile



95 mm Ø x 60 mm	<b>tk 83153-09</b>
105 mm Ø x 60 mm	<b>tk 83153-10</b>
120 mm Ø x 120 mm	<b>tk 83153-12</b>
160 mm Ø x 140 mm	<b>tk 83153-15</b>

Wattedosen mit Knopfdeckel, 18/8 rostfrei  
 Dressing jars with cover, 18/8 stainless steel

Boîtes à pansements avec couvercle, 18/8 inoxydable  
 Dispensadores de algodón, 18/8 inoxidable  
 Dispensori di cotone, 18/8 inossidabile

Verschiedene Behälter  
Different containers

Boîtes diverses  
Contentedores varios  
Vassoi diversi



0.75l	165 mm Ø x 60 mm	<b>tk 83105-15</b>
1.00l	175 mm Ø x 70 mm	<b>tk 83105-17</b>
2.00l	220 mm Ø x 80 mm	<b>tk 83105-18</b>
3.00l	240 mm Ø x 110 mm	<b>tk 83105-26</b>
4.50l	275 mm Ø x 115 mm	<b>tk 83105-28</b>
6.00l	290 mm Ø x 125 mm	<b>tk 83105-30</b>
6.00l	310 mm Ø x 120 mm	<b>tk 83105-32</b>
8.50l	345 mm Ø x 125 mm	<b>tk 83105-36</b>
11.00l	380 mm Ø x 130 mm	<b>tk 83105-39</b>

Schüsseln und Laborschalen, matt, 18/8 rostfrei  
Bowls, tarnished, 18/8 stainless steel

Coupoles, depoli, 18/8 inoxydable  
Palanganas, 18/8 inoxidable  
Scodelle, inossidabile 18/8



0.05l	40 mm Ø x 19 mm	<b>tk 83110-02</b>
0.07l	61 mm Ø x 30 mm	<b>tk 83110-05</b>
0.14l	80 mm Ø x 40 mm	<b>tk 83110-09</b>
0.35l	116 mm Ø x 50 mm	<b>tk 83110-13</b>
0.45l	128 mm Ø x 55 mm	<b>tk 83110-15</b>
0.70l	147 mm Ø x 65 mm	<b>tk 83110-20</b>



170 mm x 95 mm x 25 mm	<b>tk 83165-17</b>
200 mm x 95 mm x 30 mm	<b>tk 83165-20</b>
250 mm x 125 mm x 35 mm	<b>tk 83165-25</b>
275 mm x 140 mm x 40 mm	<b>tk 83165-27</b>

Nierenschalen, matt, 18/8 rostfrei  
Kidney bowls, tarnished, 18/8 stainless steel

Haricots, depoli, 18/8 inoxydable  
Riñoneras, 18/8 inoxidable  
Baccinella reniforme, 18/8 inossidabile



Bitte fordern Sie unseren Spezialkatalog an.  
Please ask for our special catalogue.

Veuillez demander pour notre catalogue spécial.  
Por favor preguntan para el catalogo especial.  
Per favore domandate per il nostro catalogo speciale.